

**FRONT VIEW**

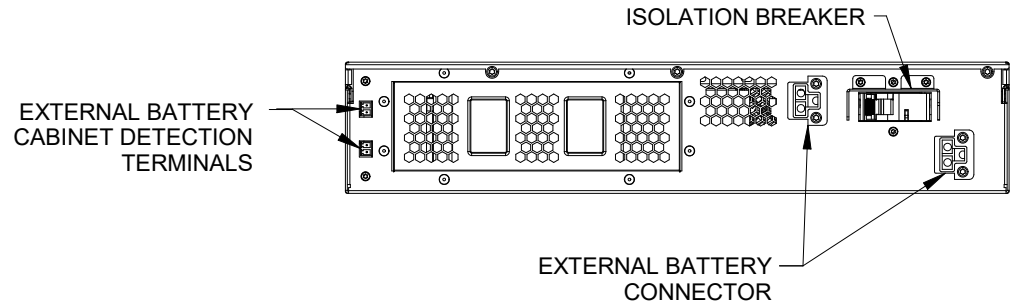

**REAR VIEW**

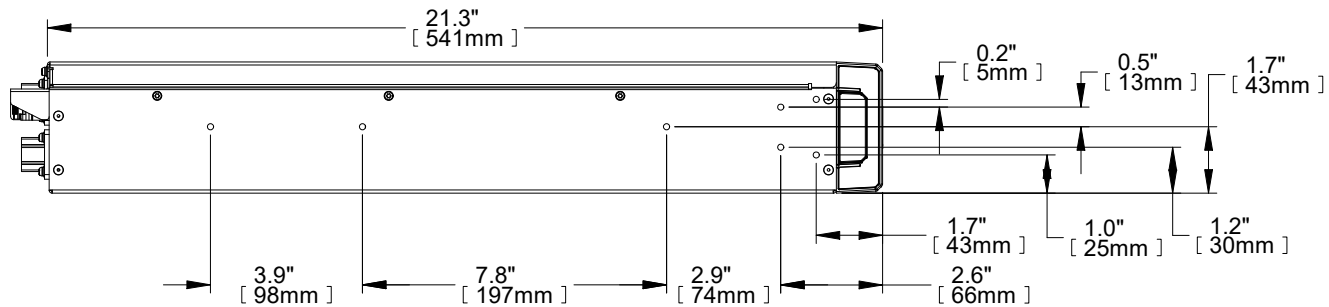

**SIDE VIEW**

**NOTES:**

1. UNIT DIMENSIONS (WxDxH): 16.9" x 21.3" x 3.3" (2U)  
(430mm) x (541mm) x (85mm)
2. UNIT WEIGHT: 90.64lbs (41.2kg)
3. SHIPPING DIMENSIONS (WxDxH): 22.4" x 28.2" x 10.3"  
(570mm) x (717mm) x (262mm)
4. SHIPPING WEIGHT: 104.72lbs (47.6kg)
5. MINIMUM AIRFLOW CLEARANCE IS 4.0" (100mm) FRONT AND REAR.

DRAWN BY B. LAY	SHEET NO. 1 OF 1
CHK BY M. MCCLINCY	ECN NO.
REF. DWG.	ORDER NO.

OUTLINE DRAWING  
LIEBERT GXT5  
72V EXTERNAL BATTERY CABINET

DWG. NO. GXT5-72VEBC OD	DATE 1/30/19	REV. # 0	1050 DEARBORN DRIVE P.O. BOX 29186 COLUMBUS, OHIO 43229
----------------------------	-----------------	-------------	---

